

EM430



seguì Corghi - follow Corghi

SPECIFICATIONS

- Range of diameter centering cone 4 cones: 1.7" - 5.4"
- Length of shaft: 7.1" (181 mm)
- Diameter of shaft: 1.57" (40 mm)
- Balancing cycle time: 7 sec.
- Measuring speed: 98 rpm
- Weight imbalance accuracy: 0.05 oz (1 g)
- Wheel width: 1.5 - 20"
- Wheel diameter: 1 - 26"
- Max. wheel and tire assembly width: 20" (505 mm)
- Max. wheel and tire assembly diameter: 44" (1117 mm)
- Max. wheel and tire assembly weight: 143 lbs (65 kg)
- Power supply: 115 Volts, 1 Ph, 50 Hz
- Dimensions H x W x D
(Machine only wheel hood open): 65" x 51" x 54"
- Weight: 315 lbs (150 kg)
- Dimensions H x W x D
(Shipping box): 45" x 53" x 37"
- Shipping Weight: 420 lbs (200 kg)

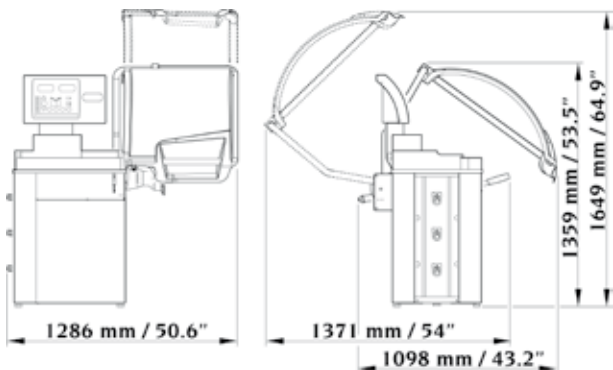

MAIN FEATURES

- Electronic balancing machine with microprocessor for off-vehicle wheels of cars, vans and motorcycles
- Low balancing speed (98 rpm) reduces wheel spin times, reduces the risks due to revolving parts and saves energy
- Wheel dimension gauge arm which positions adhesive weights in ALU P
- Manual brake for locking the wheel shaft
- Flange holder
- Cover with trays to take weights of all kinds and the most commonly used accessories
- Luminous digital dual display
- Simple, user-friendly keyboard for data input and program selection
- Processing unit with 16 bit microprocessor
- Resolution: 1 g (1/10 oz)
- Imbalance values displayed in grams or ounces
- Balancing modes available:
 - Standard dynamic on both sides of the rim
 - Alu / Alu P seven different options for alloy wheels (with profile measurement)
 - Dyn. Moto dynamic on both sides for motorcycle rims
 - Alu Moto dynamic on both sides for motorcycle alloy rims
 - Static on one plane only
- "Accelerated OPT" program for optimising wheel running noise levels
- "Hidden Weight" program (in Alu P) which subdivides the adhesive weight for the outside into two equivalent weights positioned behind the spokes of the rim.

BASIC AUTOMOTIVE ACCESSORY GROUP STANDARD WITH EM BALANCERS

- Conical Spring
- Rubber Guard for Alloy Wheels
- Wheel Attaching Cap
- Spacer Cap
- Four balancing cones
- Quick-Release Speed Nut
- Wheel Weight Hammer
- Calibration Weight/3.5 oz
- Tire Caliper

LIMITED WARRANTY

- 1 Year Parts and Labor
- 2 Years on PC Boards

